

Mercedes-Benz Unimog U 500 Euro 5

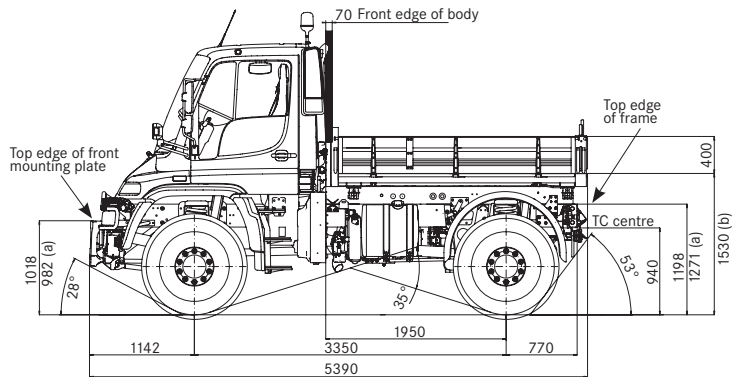

Wheelbase 3,350 mm (model variant 405.201)

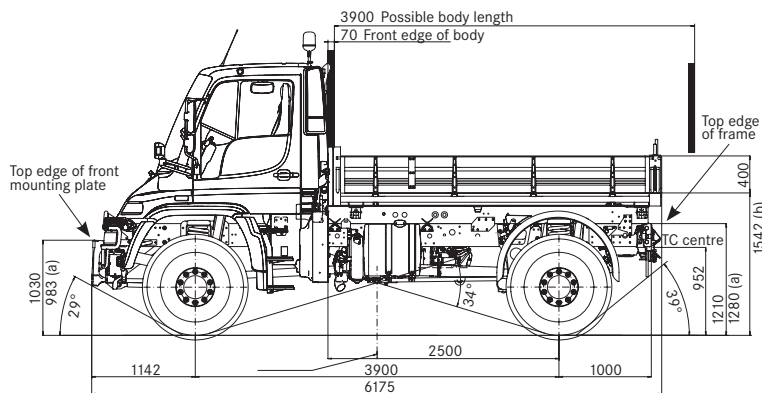
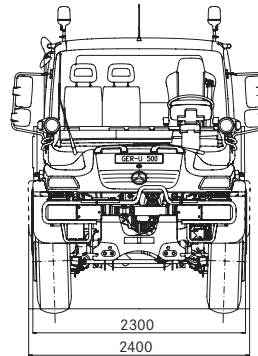

Wheelbase 3,900 mm (model variant 405.221)

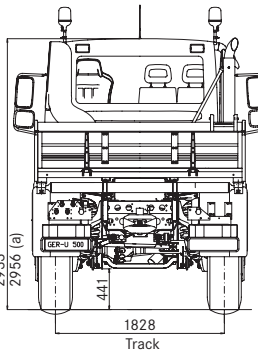

All dimensions in mm, shown with 365/85 R 20 tyres, (a) unladen, (b) with low platform intermediate frame, TC = trailer coupling

More information on the Mercedes-Benz Unimog can be found online at: www.mercedes-benz.com/unimog
Daimler AG, Special Trucks Division, 76742 Wörth, Germany, 6703.T0220/Euro 5-02-00/0609
The manufacturer reserves the right to make changes without notice. Printed in Federal Republic of Germany.

Standard equipment

Engine

- Turbocharger, intercooler
- 2 control characteristics (driving/implement mode)
- Manual throttle (electronic)
- Hydrostatic fan drive
- Euro 5 emissions standard
- 2-stage engine brake (constantly open throttle/throttle valve)
- Air compressor 310 l/min
- Air dryer
- Air filter, moisture separator
- Starter lock
- Cold start down to -16°C
- Maintenance intervals every 30,000 km (1,200 operating hours)

Clutch/transmission

- Single-plate dry clutch, self-adjusting
- 8 forward and 6 reverse gears
- Permanent all-wheel drive with lockable interaxle differential
- Telligent® gearshift
- Cruise control/speed limiter
- Max. speed limiter 90 km/h
- EQR (Electronic Quick Reverse)

Frame/axles

- Continuous, rigid ladder-type frame
- Front towing jaw with pin
- Integral subframe for front mounting plate
- Coil springs with progressive characteristic line
- Front/rear stabilisers
- Telescopic shock absorbers
- Portal axles, $i = 6.38$
- Differential lock at the rear
- Anti-corrosion underbody protection (Dinol)

Cab, exterior

- Panoramic cab, seat position behind the front axle
- Short front end dimensions
- Cab made out of corrosion-free, fibre-reinforced plastic
- Cab strength acc. to ECE R29/2
- Comfort mounting with vibration damping
- Tilting cab
- Deep-set laminated windscreen
- Deep-sill windows in the doors
- Large rear window
- Tinted glass all-round
- Power windows
- Windscreen washer system
- 3-speed windscreen wipers with intermittent setting
- Raised air intake
- Non-slip steps with grab handle
- Heated exterior mirrors, electrically adjustable

Cab, interior

- Air conditioning system with heating and ventilation system, residual engine heat utilisation
- Flat cab floor
- Stowage compartments and stowage box
- Overhead console with 2 installation openings for radio/tachograph
- 3 sun visors
- Centre console with central controls and 2 installation openings
- Combination switch on the steering column
- Instrument cluster with analogue and LCD displays
- On-board diagnostics
- Hour meter
- Seats with tailored backrest and integral head restraint
- Seats adjustable for height, length and angle, adjustable backrest, integral 3-point seat belts
- Armrest in door trim
- Interior lighting with reading lamps for driver and passengers
- 3 coat hooks
- Vehicle tools

Electrical system/lighting

- 24 V vehicle power supply
- Electronics box protected in the cab
- 24 V outlet
- CAN bus network
- Rear trailer socket, 15-pin
- Battery 135 Ah
- Electronic vehicle management system
- EMC-certified
- Three-phase generator 28 V/100 A
- Free-form headlamps
- Headlamp range adjustment
- Rear fog lamp
- Reversing lights
- End-outline marker lamps
- Additional indicators

Braking system

- Pneumatic high-pressure braking system (18 bar)
- Disc brakes on all 4 wheels
- 4-channel ABS can be deactivated off-road
- Automatic load-sensitive brake pressure control (ALB)
- Compressed air connection for auxiliary loads
- Spring-loaded parking brake
- Tyre inflation connection
- Brake pad wear indicator

In addition to this extensive standard equipment, we can also offer you a host of optional equipment and accessories to meet the specific operational needs of your Unimog. Your Unimog Partner will be happy to advise you.

Engines		175 kW, 238 hp	210 kW, 286 hp
Emissions class		Euro 5	Euro 5
Model		OM 906 LA	OM 906 LA
Type		4-stroke diesel direct injection with turbocharger/intercooler	
No. of cylinders/arrangement		6, in-line	6, in-line
Displacement	cc	6,370	6,370
Max. output	kW (hp)	175 (238)	210 (286)
at rated engine speed	rpm	2,200	2,200
Max. torque	Nm	850	1,120
Cooling system		Water with thermostat, hydrostatic fan drive	
Diesel fuel tank	Net capacity (litres)	190 (opt. 240)	190 (opt. 240)
AdBlue tank	Net capacity (litres)	25	25

Transmission

- MB full-synchromesh reversing transmission with 8 forward and 6 reverse gears
- Opt. additional 8 fully loadable working gears and 8 crawler gears
- Opt. electronic AutomaticShift system
- Opt. hydrostatic drive, module operation

Speeds (in km/h, forward)

Main gears	7.0	-	90.0
Working gears	1.2	-	15.8
Crawler gears	0.13	-	1.64

with 385/65 R 22.5 tyres and final drive ratio $i = 6.38$

Electrical system 24 V

- Battery 2 x 12 V/135 Ah
- Opt. 24 V/25 A and 12 V/15 A outlets with C3 signals
- Opt. 24 V/40 A equipment socket, 24-pin with C3/C4 signals

Steering

- Hydraulic power steering, type: LS 6
- Opt. right-hand drive
- Opt. VarioPilot® transferable steering system
- Turning circle Ø short wheelbase from 15.0 m
- Turning circle Ø long wheelbase from 16.8 m

Axles/drive

- Front/rear portal axles on trailing links and wishbones
- Opt. differential lock at front axle
- All locks can be selected and deactivated electropneumatically while in motion using a dog clutch (100% locking factor)

Cab

Exterior

- Optimum all-round visibility for working with implements • Opt. hydraulic tilt cab • Opt. heated windscreen • Opt. mowing door instead of right-hand door • Opt. vertical exhaust pipe

Interior

- **Seats** • Opt. driver and passenger seats as heated, air-sprung luxury suspension seat • Opt. passenger seat as two-seater version; provides 3 seats with integral seat belts • Opt. swivel seat in conjunction with the mowing door on the passenger side
- **Air conditioning** • Opt. pollen filter • Opt. auxiliary heating with engine preheating, 7-day timer
- **Instruments, controls** • Driver information system (FIS) with status displays, event reports and menu-driven on-board diagnostics • 2-line indicator lamps, visual and acoustic warning indicators • Opt. digital tachograph

- **Safety** • Safety locks in the doors, steering and ignition lock • Opt. electronic immobiliser

Lighting

- Opt. auxiliary headlamps with indicator lamps for implement operation
- Opt. rear floodlight
- Opt. rotating beacons

Wheels/tyres

- 4 identical size tyres; single tyres
- Opt. low-pressure tyres with truck/AS/MPT treads
- Standard tyres 385/65 R 22.5
- Smallest tyres 365/80 R 20
- Largest tyres 455/70 R 24
- Opt. tyre pressure control system (tirecontrol) to adjust the tyre pressure to on-road/off-road

Max. permissible loads (in tonnes up to)

Perm. GVW	Front	Rear
11.99	6.7	7.2
14.0	7.2	7.2
15.0	7.2	8.5
16.0	7.5	9.5 subject to regulations

Towing capacity

- Opt. dual-line trailer braking system
- As truck up to 24 t, with centre axle trailer up to 18 t
- As tractor up to 28 t, with centre axle trailer up to 18 t

Hydraulics (optional)

Working or common hydraulics

- acc. to EN 15431 for positioning movements and continuous loads (supplied as hydraulic packages)
- Single-circuit hydraulic system, with 48 l/min flow rate and 200 bar operating pressure
- Dual-circuit hydraulic system with proportional control, circuit I/II, with 24/48 l/min flow rate and 200/240 bar operating pressure
- Oil reservoir 45 l (consumption quantity 10 l)
- Circuit I controlled via 2 to 4 double-acting valves with floating position

- Up to max. 4 cells operated via joystick and switch, flow rate selection, flow summation
- Snowplough load relief to reduce the contact pressure when clearing snow
- Tipping cylinder with isolating valve and connections at the rear

Power hydraulics

- for continuous loads demanding high power
- Circuit III (closed circuit) from 0 to 125 l/min flow rate and 300 bar operating pressure
- Circuit IV (open circuit) from 0 to 90 l/min flow rate and 280 bar operating pressure
- Circuit III and IV operating in tandem

Auxiliary drives (optional)

PTO shaft at the front

- Direct, mechanical power take-off from the engine drive train, power-shiftable, standard speed 540/1000 rpm
- Rotates clockwise in the direction of travel
- Continuous output 150 kW
- Profile 1¼ inch, splined shaft

Transmission-mounted auxiliary drive

- Mechanical transmission-mounted auxiliary drive to power hydraulic pumps
- High-speed PTO with $i = 1.0$
Speed 2,200 rpm, rotates anticlockwise in the direction of travel
Max. torque 650 Nm/max output 150 kW
- or
- Ultra-high-speed PTO with $i = 0.61$
Speed 3,606 rpm, rotates clockwise in direction of travel
Max. torque 320 Nm/max. output 120 kW

Implements and attachments (optional)

- Opt. front mounting plate acc. to DIN EN 15432, type F1c or acc. to DIN 76 060, type B, size 3
- Opt. frame attachment fittings/brackets, centre, rear and between the axles
- Opt. 3-sided tipper platform

opt. = optional